

2500 Gallon Below Ground Holding Tank Installation Instructions

THIS TANK IS NOT TO BE USED ABOVE GROUND

1. EXCAVATION

- Excavate to a depth that will provide a minimum of 6" and a maximum of 24" of cover over the top of the tank.
- Allow 18" to 24" on both sides and both ends of the tank.
- Bed the tank in well-compacted sand – 6" minimum in soil terrain, 12" minimum in rock terrain.

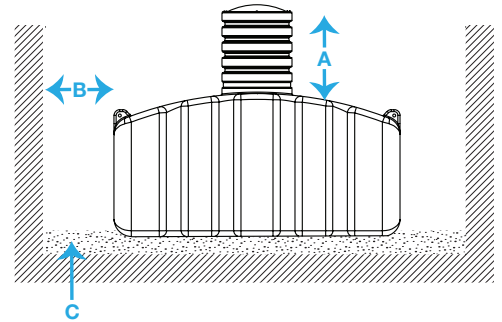

2. CONNECTIONS TO TANK

- Install fittings in any location required for holding tank use.
- Contact factory for approval if multiple fittings are installed in close proximity.
- Tank must be vented.
- For water-tight seal, lid should be sealed with silicone or urethane caulking. Re-use stainless steel screws supplied with lid to re-attach lid to tank.

3. MANHOLE EXTENSION

- Install manhole extension before you backfill.
- Norwesco manhole extensions are supplied with gaskets and screws. Re-use the stainless steel screws to attach the lid at the top of the manhole extension.

4. BACKFILLING EXTERIOR

- Backfill with 12" layers and compact each layer. Always compact ends first.
- Each of the six interior support cones must be filled and compacted in 6" layers; the bottom half of the cones are tapered and must have the soil compacted to provide structural support. See diagram.
- Maximum backfill over the top of the tank is 24". Mound soil over the top to provide positive drainage.

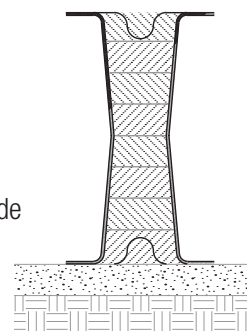

Fill Cones in 6" layers from the bottom up, compact each layer. Use recommended backfill material.

5. BACKFILL MATERIALS

- The preferred material for backfilling, surrounding and covering the tank is a sand and gravel mixture—100% smaller than 1½" and approximately 50% smaller than ¼". Native soil can be used if this mixture is not available.
- All fill must be free of any wood, masonry debris, silt or clay. Sharp objects must not come in contact with the wall of the tank.

CAUTION

Failure to comply with the points below voids warranty.

- A.** Maximum burial depth is 24 inches.
- B.** Do not install tank in water-saturated clay or in high water table.
- C.** Do not install tank across the path of vehicles or heavy equipment.
- D.** Protect tank from sharp objects which could puncture it and cause leakage.
- E.** Tanks are not fire-resistant. Do not store them near an open flame or in heat in excess of 180° F.
- F.** Do not lift tank by lugs unless tank is empty. Always lift using 4 lugs simultaneously.

Norwesco advises against the use of a plastic underground tank for any other uses! Such uses would void any Norwesco product warranty either stated or implied. In no event shall Norwesco be held liable for any consequential damages.

WARRANTY

underground tanks, when installed in accordance to manufacturer's instructions, are warranted against defective materials and/or workmanship for a full three (3) years from date of manufacture. Should a defect appear within the warranty period, Norwesco will supply a new, equivalent tank in replacement thereof. Norwesco's liability is limited to the value of the tank itself and specifically excludes the cost of installation and/or removal and consequential damages.
