

U.N. MARKING ON TANK READS:

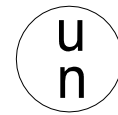

31H1 / Y / MO. / YR. / USA
 SNYDER IND. INC.
 LINCOLN, NE. 4518 / 1702
 CAPACITY - 833 LITERS
 TARE MASS - ACTUAL KG
 GAUGE TEST PRESSURE - 100 KPA
 LAST LEAKPROOFNESS TEST - MO. / YR.
 LAST INSPECTION - MO. / YR.

220 STANDARD ULTRATAINER "STANDARD PACKAGE OF OPTIONAL EQUIPMENT"

ITEM #	DESCRIPTION	QTY.	PART NUMBER
1	TANK - 2 BUNG TANK WITH 6" HEAVY DUTY CAP AND BOTTOM DRAIN HDPE NATURAL. (WITH CAP LANYARD INSERT AND WITH TAMPER EVIDENCE INSERTS MOLDED IN)	1	68245
2	BASE - BASE 220 STANDARD ULTRATAINER HD/BLUE	1	685179
3	TOP PROTECTOR ULTRA HD/BLUE	1	670179
4	PIN ASSEMBLY PURCHASED PLASTIC W/BOLTS FOR ULTRA.	1	347905
5	S.I.I. PROPRIETARY 2" NPS REPLACEABLE BUNG GLASS FILLED POLYETHYLENE W/ITON O-RING SEAL	2	N/A
6	2" NPS RIEKE POLYETHYLENE BUNG PLUGS WITH EPDM FLAT GASKETS	2	347340
7	6" HEAVY DUTY CAP WITH 2" NPS CENTER OPENING AND EPDM CAP GASKET. EQUIPPED WITH LID TIE	1	347391
8	S.I.I. 2" NPS VACUUM RELIEF VENT WITH EPDM DISK AND FLAT GASKET (AVERAGE GRAVITY FLOW RATE OF 70 GALLONS PER MINUTE)	1	347854
9	2" BANJO STANDARD PORT GLASS FILLED POLYPROPYLENE BOTTOM DRAIN VALVE WITH TEFLON SEATS AND BALL AND 18/8 S.S. BOLTS. INCLUDES DUST CAP AND CAP LANYARD.	1	347718

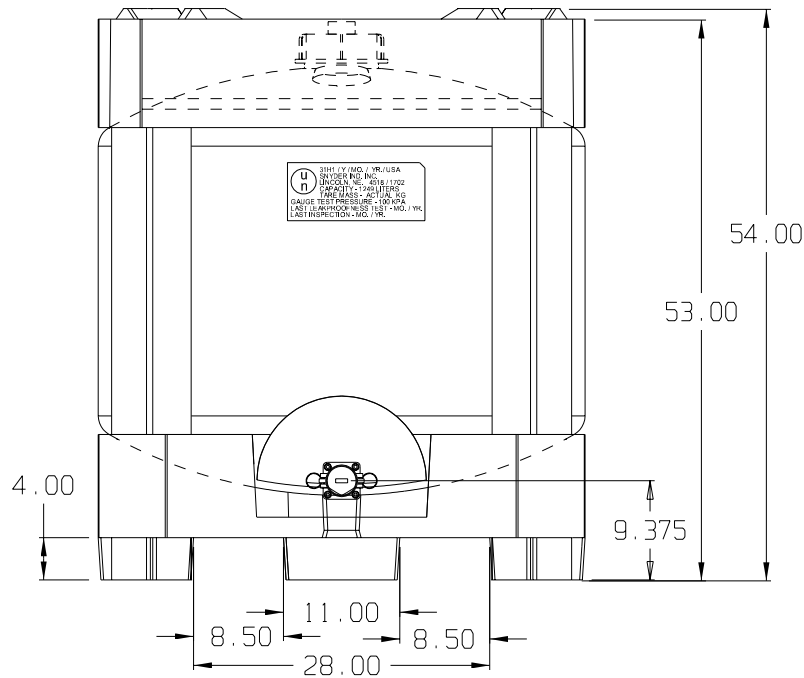

(all dimensions in inches)
 (all dimensions nominal)

FORK OPENING DIMENSIONS ARE THE SAME ON ALL FOUR SIDES OF THE CONTAINER.

PART # TANK: 68245

220 GALLON STANDARD ULTRATAINER W/HD 6" CAP

REF#: 0000

08/16/02

SNYDER INDUSTRIES INC.