

Copyright. All information furnished within this document, electronic file or design correspondence is the property of Den Hartog industries, Inc. and shall not be used, disclosed to others or copied without the expressed written consent of Den Hartog Industries, Inc.

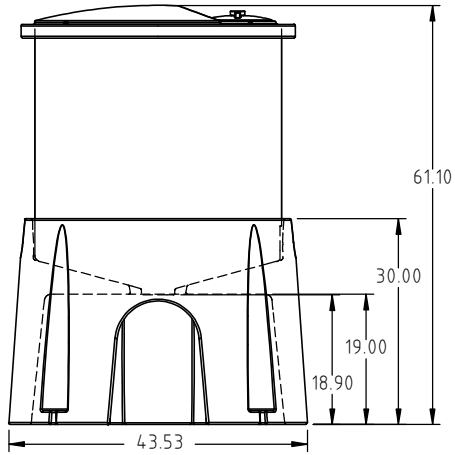

OC036-STP POLY STAND

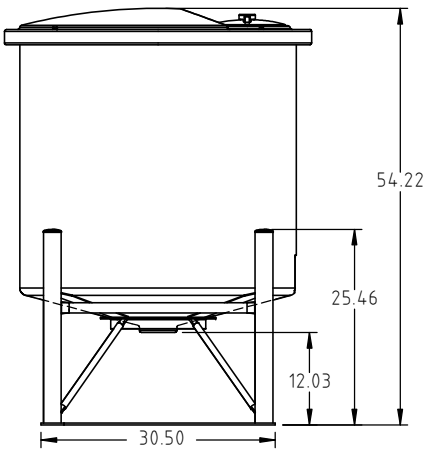

CB036-15ST METAL STAND

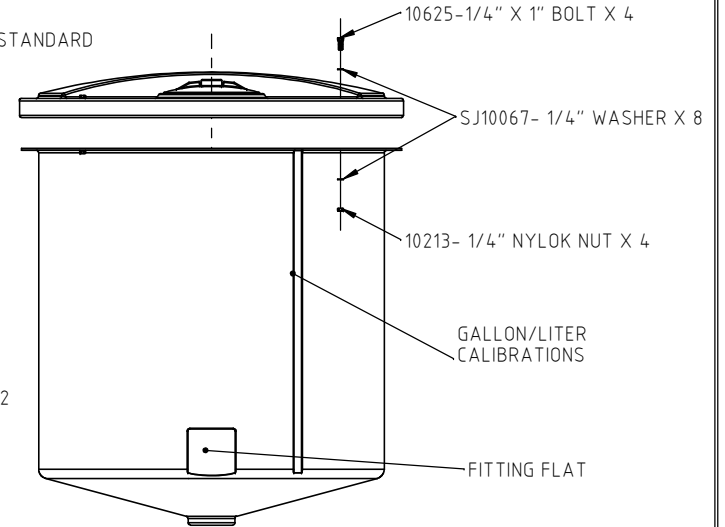
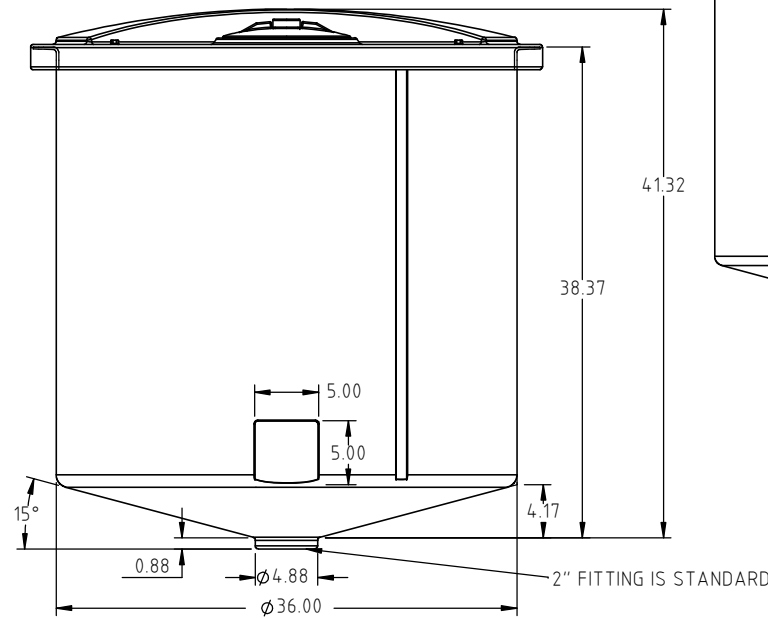
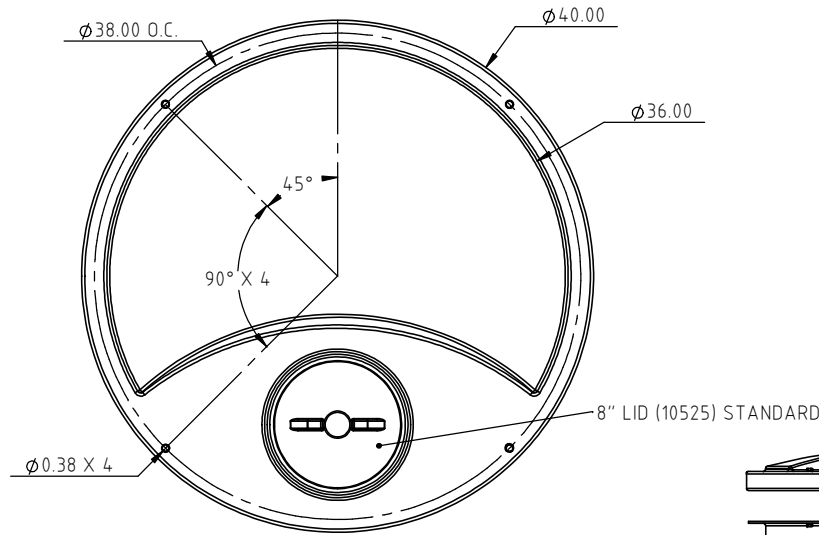

REV	DESCRIPTION	BY / DATE	CCN

ALL DIMENSIONS ARE IN DECIMAL INCHES
TOLERANCES UNLESS OTHERWISE SPECIFIED

POLYETHYLENE	METAL DECIMAL ± .125" FRACTION ± 1/4" ANGLE ± 1°
--------------	---

±1% @ 68°F

DRAWN / DATE ADH 2/11/11	MATERIAL 104-20
APPROD. / DATE REH 4/18/11	
SHOT WEIGHT: 50.00 LBS	NOTES: 1) 0.20 WALL THICKNESS
SHIPPING WEIGHT: 52.00 LBS	
FINISH:	

THIRD ANGLE PROJECTION ANSI 14.5M	



Den Hartog

INDUSTRIES, INC.

Acra Roto-Mold Injection Molding Blow Molding Sowjey

4010 HOSPERS DRIVE S. BOX 425, HOSPERS, IOWA 51238-0425

DESCRIPTION	36" DIA. X 145 GALLON CONE BOTTOM- OPEN TOP	
SCALE	N.S.	PART NO. OC0145-36