

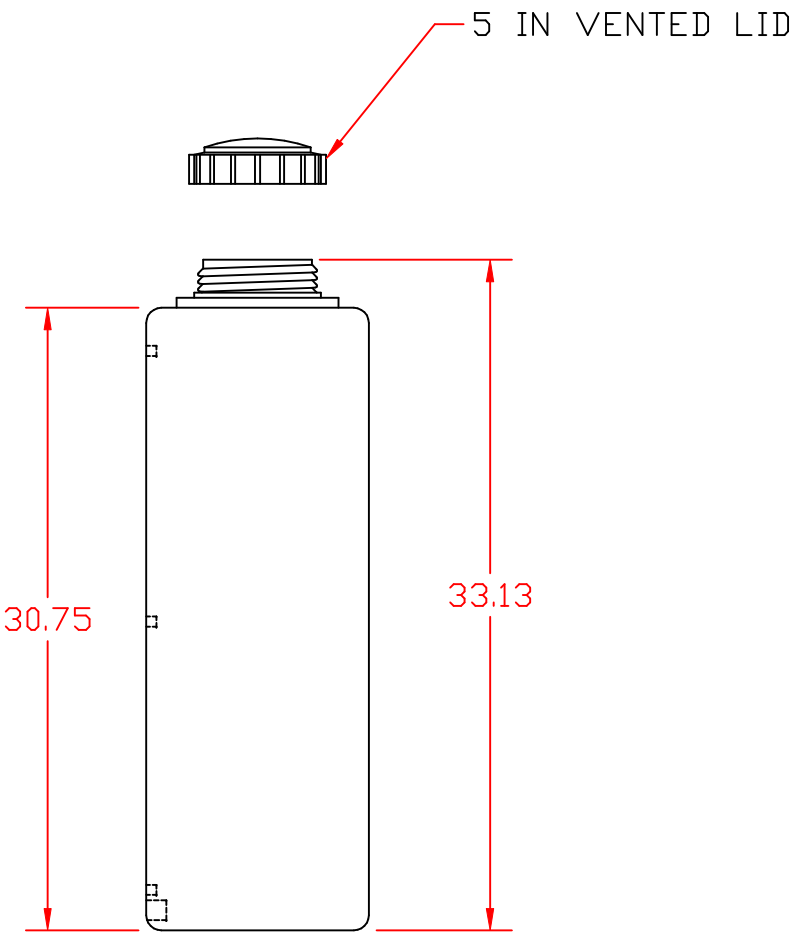
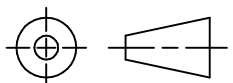

1/2-14 NPT INTERNAL



		DRAWN / DATE DHJ/1/7/03		MATERIAL / SHOT WEIGHT		 Ace Roto-Mold A DIVISION OF DEN HARTOG INDUSTRIES, INC.	
		APPRD. / DATE REH/1/7/03		16 LBS.			
REV	DESCRIPTION	DATE	APPRD.	THIRD ANGLE PROJECTION ANSI 14.5M		CLIENT / DESCRIPTION	
ALL DIMENSIONS ARE IN DECIMAL INCHES TOLERANCES UNLESS OTHERWISE SPECIFIED ±1% @ 68° F						20 GALLON RECTANGLE	
				NOTES: 1. NOM. WALL .230		SCALE NONE	PART NO. SP0020-DM