

© DEN HARTOG INDUSTRIES, INC.

Copyright. All information furnished within this document, electronic file or design correspondence is the property of Den Hartog Industries, Inc. and shall not be used, disclosed to others or copied without the expressed written consent of Den Hartog Industries, Inc.

SP1000-UT

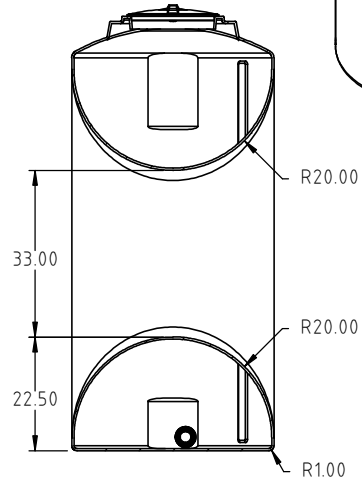
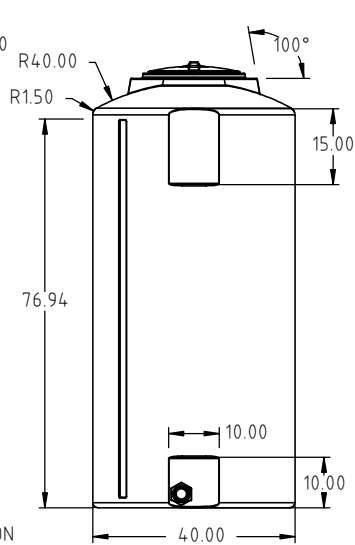
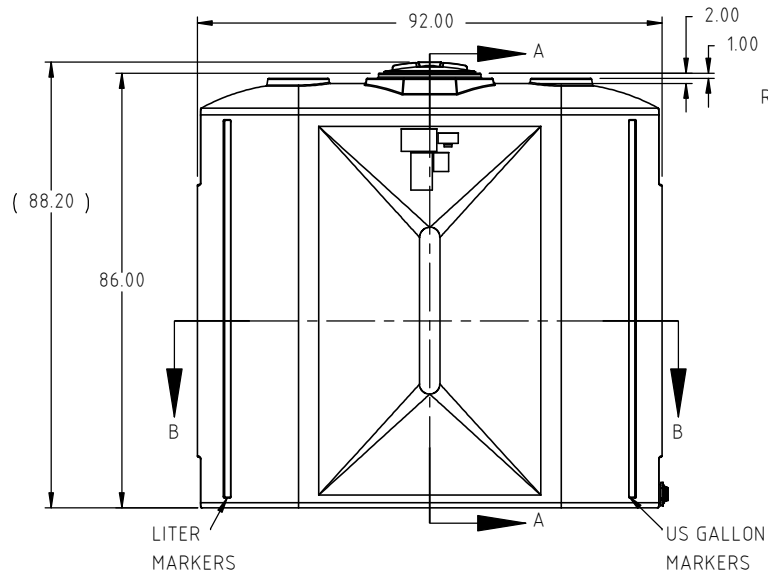
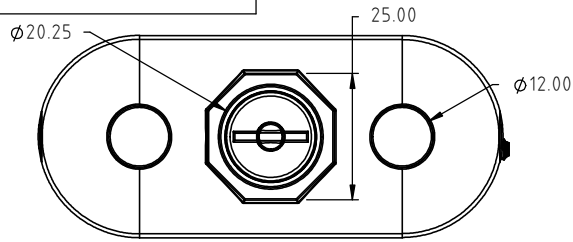

SECTION A-A
SCALE 1 : 38

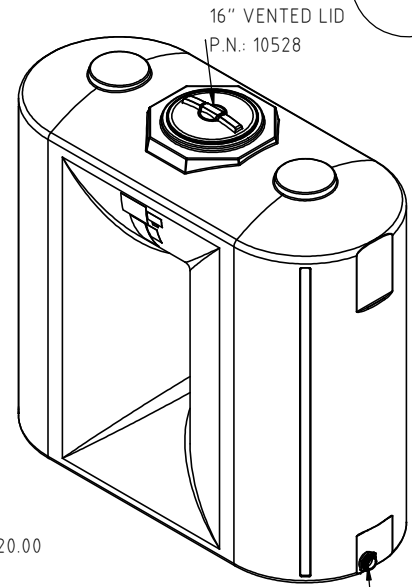

2" FPT FITTING
IS STANDARD.
P.N.: 10508
(OFFSET FROM P/L)

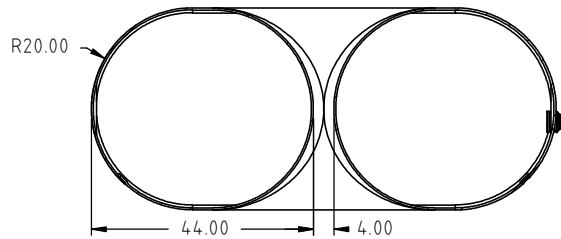

SECTION B-B
SCALE 1 : 38

				DRAWN / DATE ADH 9/26/17	MATERIAL
				APPRD. / DATE REH 3/13/18	10538
REV	DESCRIPTION	BY / DATE	CCN	SHOT WEIGHT: 405 LBS.	NOTES: 1.) NOM. WALL .425
				SHIPPING WEIGHT: 407 LBS.	
				FINISH:	



Den Hartog INDUSTRIES, INC.

Acra Roto-Mold Injection Molding Blow Molding Sowjoy

4010 HOSPERS DRIVE S. BOX 425, HOSPERS, IOWA 51238-0425

DESCRIPTION	1000 GALLON UTILITY TANK	
SCALE	N.S.	PART NO. SP1000-UT

ALL DIMENSIONS ARE IN DECIMAL INCHES
TOLERANCES UNLESS OTHERWISE SPECIFIED

POLYETHYLENE METAL
DECIMAL ± .125"
FRACTION ± 1/4"
ANGLE ± 1°

THIRD ANGLE PROJECTION
ANSI 14.5M

