

# Ace Roto-Mold

June 2018

## **NEW** PRODUCT RELEASE

### **4200 Gallon Elliptical Leg Tank** FS4200-92 / FM4200-92

New product is a freestanding elliptical tank with legs for indoor or outdoor, stationary or transportable applications. Five hoop recesses are provided around the tank to facilitate anchoring. Gallon indicators are included on one side and end of the tank. The tank features a sump on each end for fitting location. Poly baffles are included for fluid control. FM style tanks feature a choice of center or end drain bottom sumps.

Tank is designed for the containment of all chemicals rated for contact with polyethylene. Tank must be installed with 5 hoops securely anchored to the tank base or stand. Standard weight tank is designed for chemicals with a specific gravity of 1.7. FDA compliant materials are available.

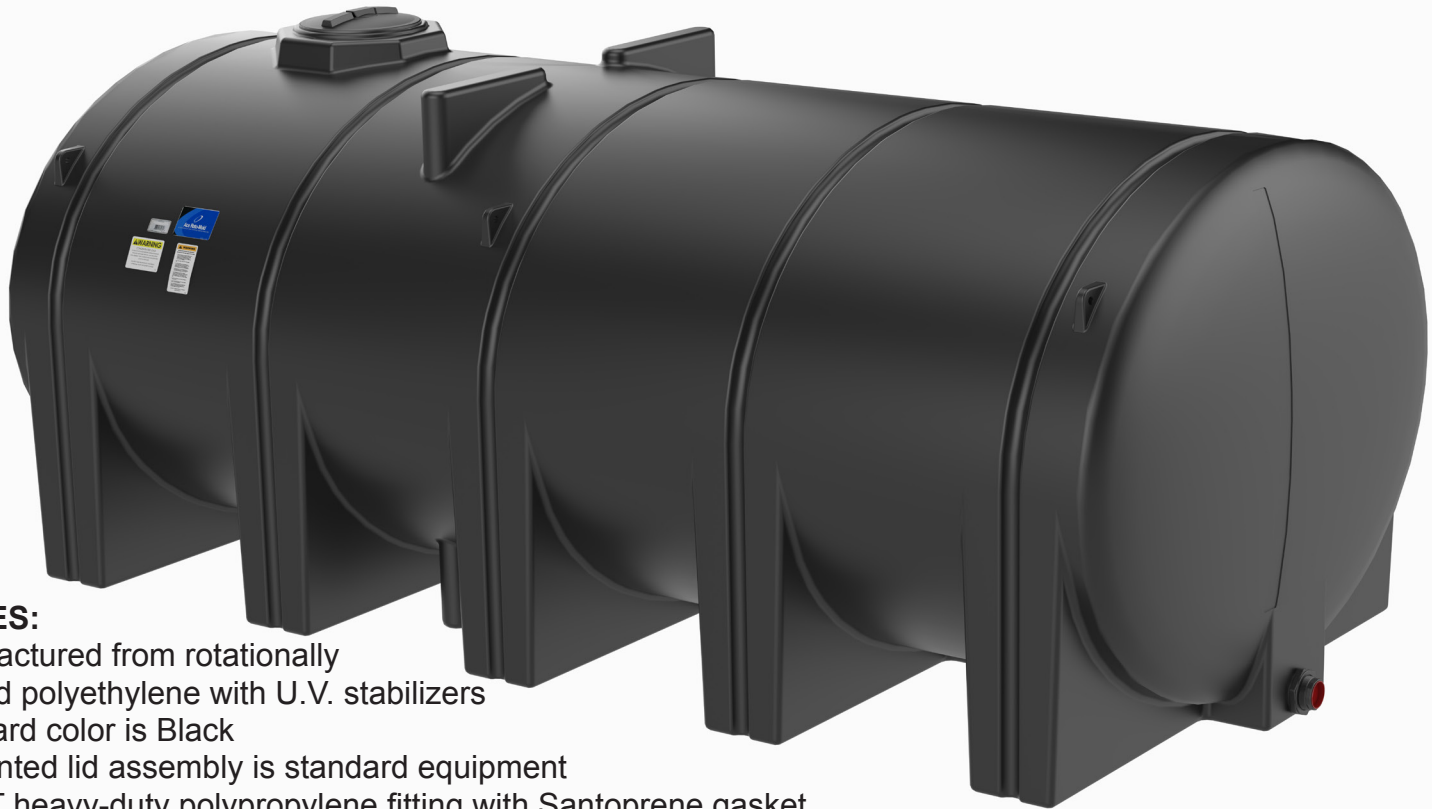

#### **FEATURES:**

- Manufactured from rotationally molded polyethylene with U.V. stabilizers
- Standard color is Black
- 16" vented lid assembly is standard equipment
- 3" FPT heavy-duty polypropylene fitting with Santoprene gasket and siphon tube is standard equipment

#### **SPECIFICATIONS:**

- Dimensions: 92" wide x 194.5" long x 80" tall
- Weight of tank and baffles is 1,648 lbs.
- Weight of Hoop kit option is 186 lbs.
- Skid option SKO/SKCO/SKEO weighs 1,454 lbs.

 **Den Hartog**  
INDUSTRIES, INC.  
*"Always at Your Service"*

Ph: 800-342-3408  
Fax: 712-752-8222

[www.denhartogindustries.com](http://www.denhartogindustries.com)  
[sales@denhartogindustries.com](mailto:sales@denhartogindustries.com)

4010 Hospers Dr. South  
Hospers, IA 51238

# 4200 Gallon

## *Elliptical Leg Tank*

### *SPECIFICATION DETAILS*

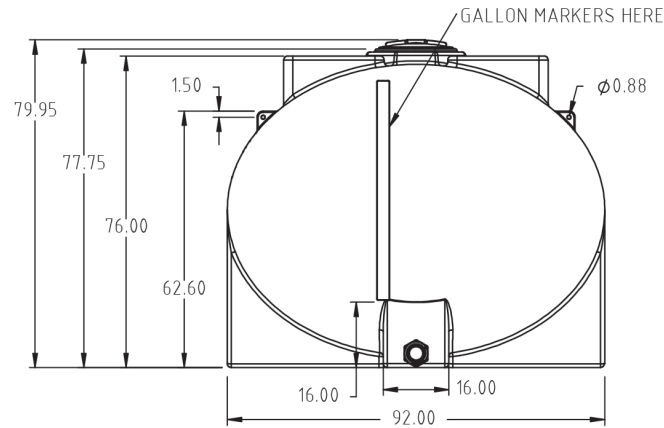
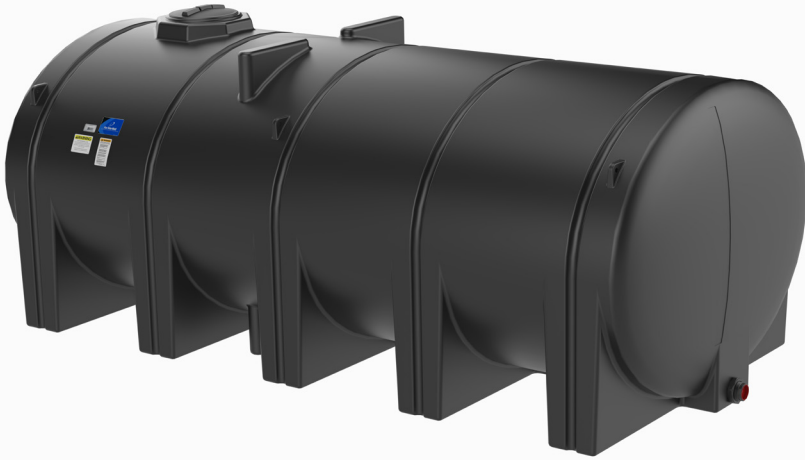

HOOPS ARE REQUIRED WITH THIS TANK

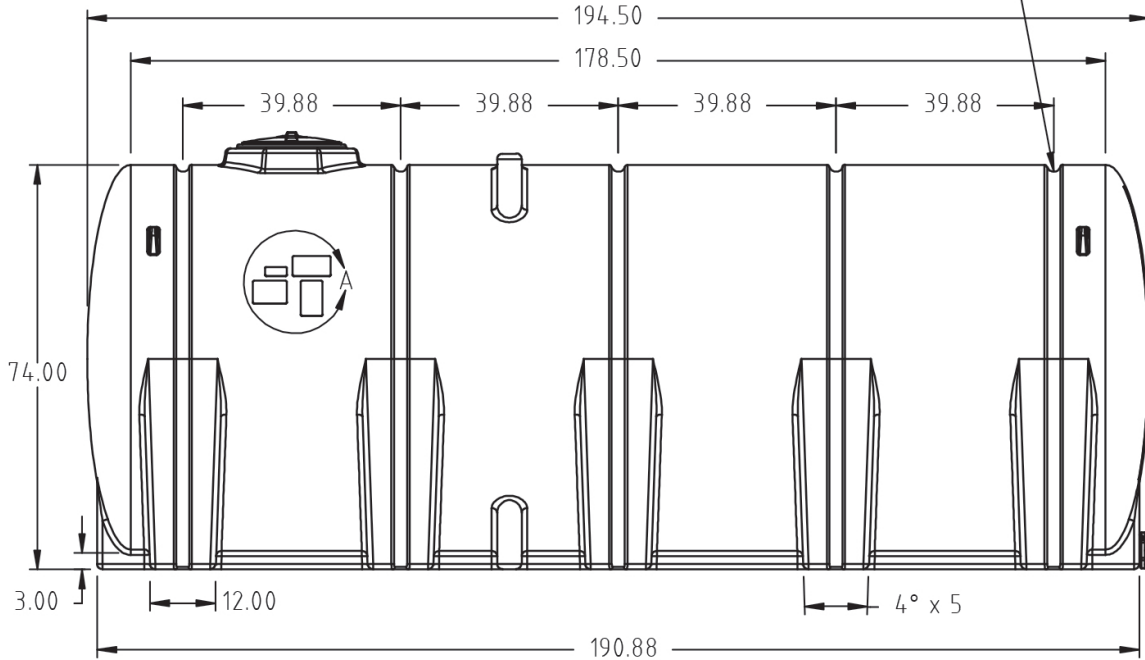

**OPTIONAL SKID**

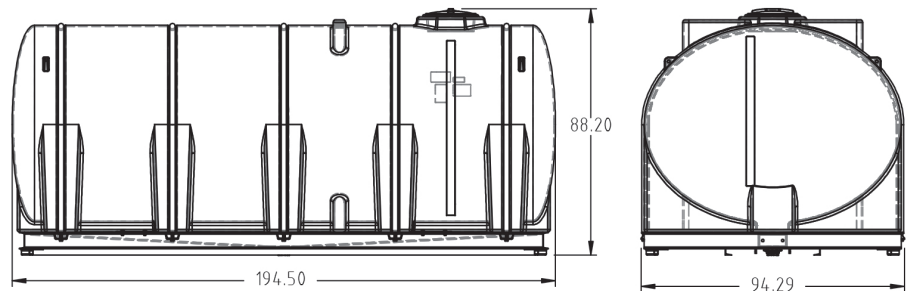

**Den Hartog**  
INDUSTRIES, INC.  
"Always at Your Service"

Ph: 800-342-3408  
Fax: 712-752-8222

[www.denhartogindustries.com](http://www.denhartogindustries.com)  
[sales@denhartogindustries.com](mailto:sales@denhartogindustries.com)

4010 Hospers Dr. South  
Hospers, IA 51238