

Copyright. All information furnished within this document, electronic file or design correspondence is the property of Den Hartog Industries, Inc. and shall not be used, disclosed to others or copied without the expressed written consent of Den Hartog Industries, Inc.

LID TRIM AND FASTENING DETAIL

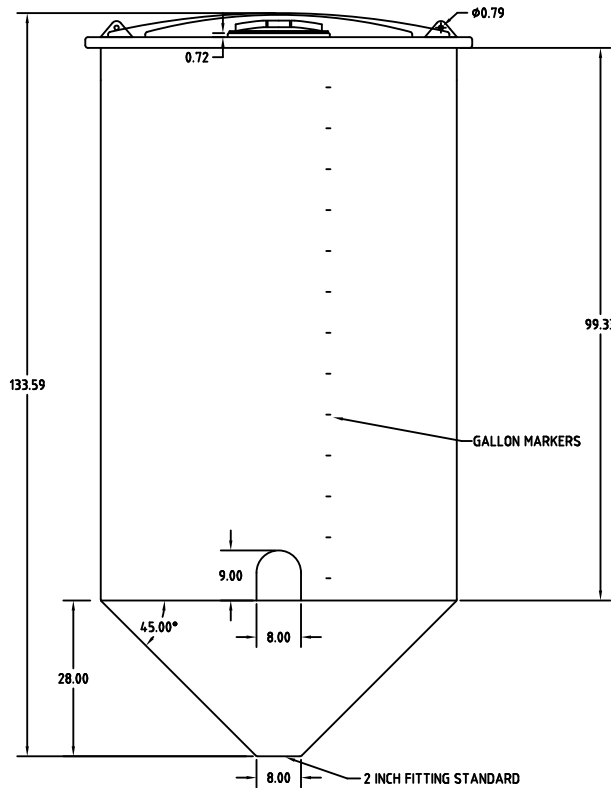
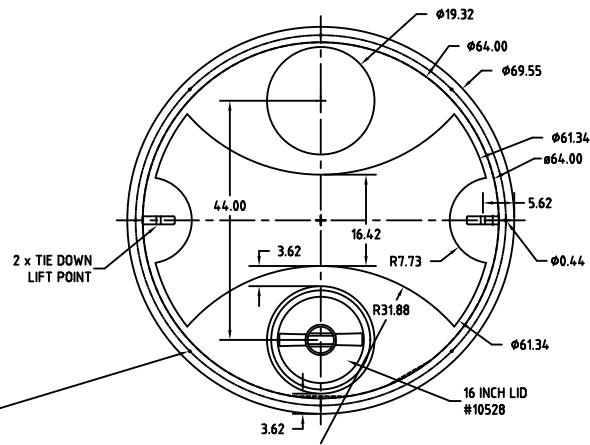
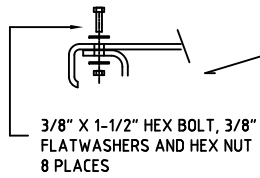
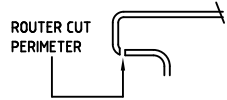

REV	DESCRIPTION	BY / DATE	CCN
ALL DIMENSIONS ARE IN DECIMAL INCHES TOLERANCES UNLESS OTHERWISE SPECIFIED			
POLYETHYLENE		METAL	
$\pm 1\%$ @ 68° F		DECIMAL $\pm .125$ " FRACTION $\pm 1/4$ " ANGLE $\pm 1^\circ$	

DRAWN / DATE	DHJ 2/3/12
APPRD. / DATE	REH 3/6/12
SHOT WEIGHT:	340 LBS.
SHIPPING WEIGHT:	342 LBS.
FINISH:	

MATERIAL	10420
NOTES:	1. .37 WALL



Den Hartog

INDUSTRIES, INC.

Ace Roto-Mold Injection Molding Blow Molding Sowjoy

4010 HOSPERS DRIVE S. BOX 425, HOSPERS, IOWA 51238-0425

DESCRIPTION		1500 GALLON OPEN CONE WITH BOLT ON TOP	
SCALE	N.S.	PART NO.	OC1500-64

