

Copyright. All information furnished within this document, electronic file or design correspondence is the property of Den Hartog industries, Inc. and shall not be used, disclosed to others or copied without the expressed written consent of Den Hartog Industries, Inc.

LID TRIM AND FASTENING DETAIL

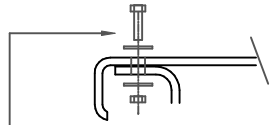

3/8" X 1-1/2" HEX BOLT, 3/8" FLATWASHERS AND HEX NUT 12 PLACES

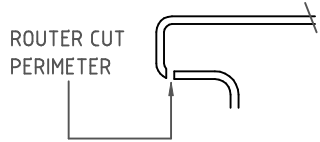
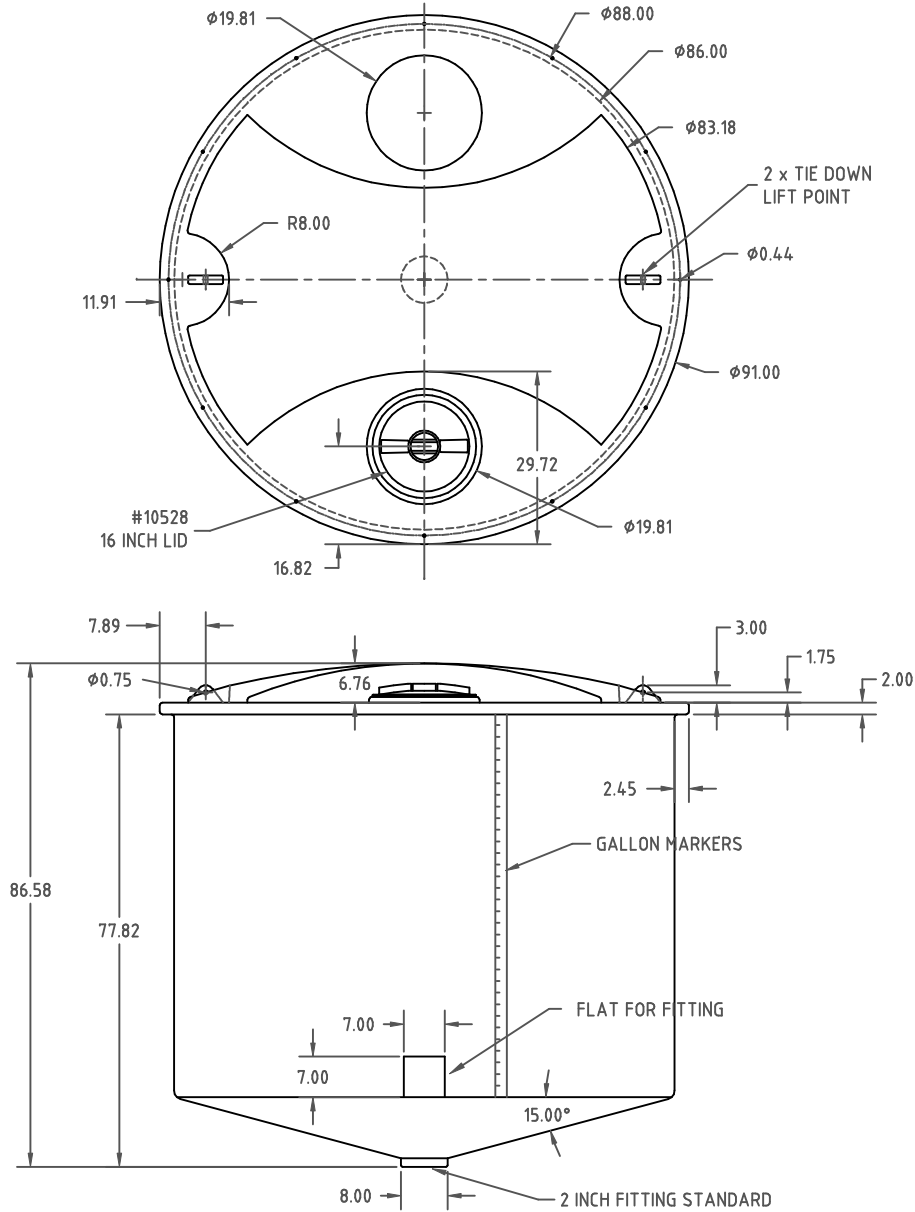

REV	DESCRIPTION	BY / DATE	CCN
	ALL DIMENSIONS ARE IN DECIMAL INCHES TOLERANCES UNLESS OTHERWISE SPECIFIED		
	<u>POLYETHYLENE</u>		
	METAL DECIMAL ± .125" FRACTION ± 1/4" ANGLE ± 1°		

DRAWN / DATE DHJ 4/27/11
APPRD. / DATE REH 5/10/11
SHOT WEIGHT: 284 LBS.
SHIPPING WEIGHT: 286 LBS.
FINISH:

MATERIAL 104-20
NOTES: 1. .290 THICK AT BOTTOM SIDE WALL



Den Hartog

INDUSTRIES, INC.

Ace Roto-Mold Injection Molding Blow Molding Sowjoy
4010 HOSPERS DRIVE S. BOX 425, HOSPERS, IOWA 51238-0425

DESCRIPTION 1710 GALLON CONE BOTTOM OPEN TOP TANK	
SCALE N.S.	PART NO. OC1710-86

