

Copyright. All information furnished within this document, electronic file or design correspondence is the property of Den Hartog industries, Inc. and shall not be used, disclosed to others or copied without the expressed written consent of Den Hartog Industries, Inc.

LID TRIM AND FASTENING DETAIL

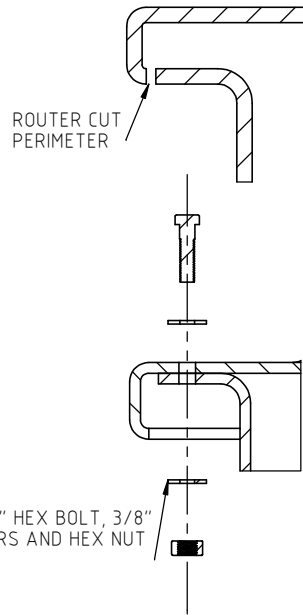

3/8" X 1-1/2" HEX BOLT, 3/8" FLATWASHERS AND HEX NUT 12 PLACES

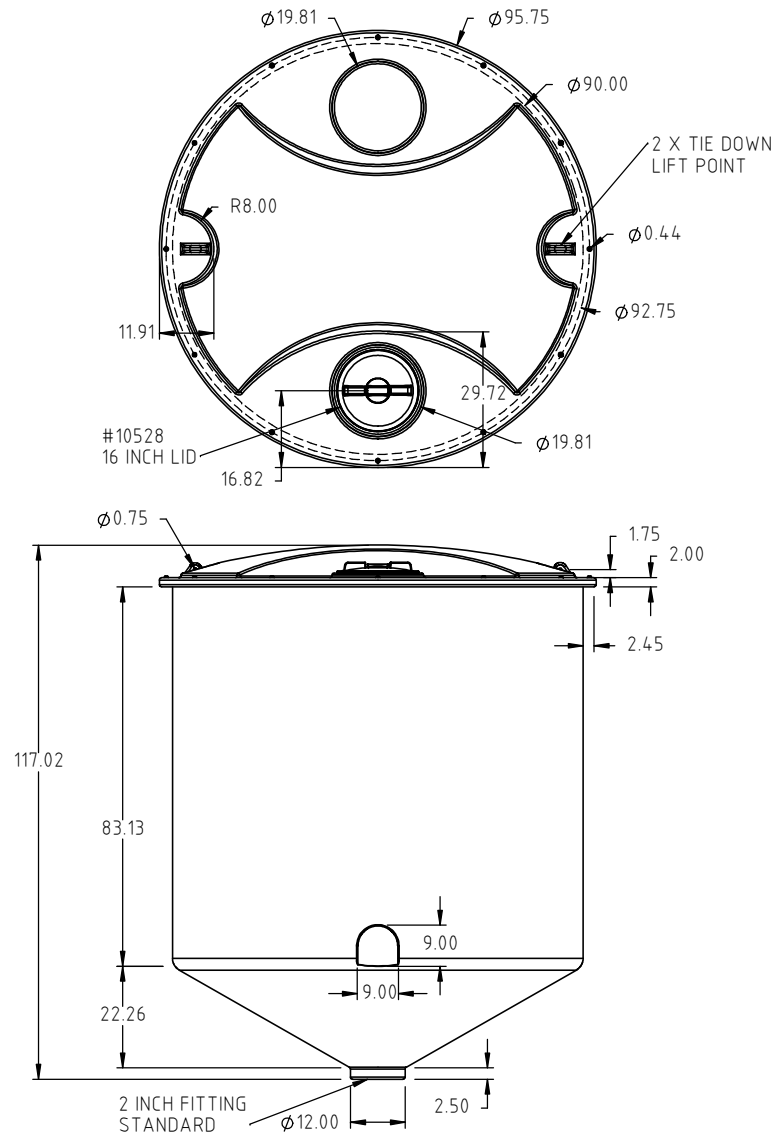

				DRAWN / DATE DHJ 2/3/12	MATERIAL 10420
				APPRD. / DATE REH 7/12/12	
REV	DESCRIPTION	BY / DATE	CCN	SHOT WEIGHT: 500.00 LBS	NOTES: 1.) 0.400" THICK
				SHIPPING WEIGHT: 502.00 LBS	
				FINISH:	
ALL DIMENSIONS ARE IN DECIMAL INCHES TOLERANCES UNLESS OTHERWISE SPECIFIED POLYETHYLENE		THIRD ANGLE PROJECTION ANSI 14.5M			
METAL DECIMAL ± .125" FRACTION ± 1/4" ANGLE ± 1°					



Den Hartog
INDUSTRIES, INC.

Acro Roto-Mold Injection Molding Blow Molding Sowjey

4010 HOSPERS DRIVE S. BOX 425, HOSPERS, IOWA 51238-0425

DESCRIPTION 2440 GALLON OPEN CONE WITH BOLT ON TOP	
SCALE N.S.	PART NO. OC2440-90